

HAFCO WOODMASTER

8" PROFESSIONAL JOINTER OPERATION MANUAL



**Model No.
P-200H**

Edition No : PJ-001

Date of Issue : 07/2017

www.machineryhouse.com.au

Table of Contents

Table of Contents	2
Warning.....	3
Identification.....	5
Specifications	5
Unpacking and Cleanup	6
Unpacking and Cleanup	6
Installing Bed to Stand	7
Installing Handwheels	7
Instakking Fende To Fence Carriage.....	8
Installing V-Belts	9
Installing Cutterhead Guard.....	10
Installing Dust Chute	10
Setting Outfeed Table Hight.....	10
Adjustments	12
90° Fence Adjustment.....	12
45° Fence Adjustment.....	12
Gib Adjustment	13
Removing and Replacing Knives.....	14
Replacing or Rotating Knife Inserts.....	14
Operation	15
Jointing Warped Material.....	16
Direction of Grain	16
Bevel Cut.....	16
Taper Cut.....	17
Rabbet Cut	17
Maintenance.....	18
Lubrication	18
Blade Care.....	18
Sharpening the Knives.....	18
Cutterhead Removal	18
Troubleshooting	19
Jointer Body Diagram and Part List.....	20
Cutterhead Diagram and Part List.....	21
Fence Diagram and Part List.....	22
Stand Diagram and Part List.....	23



Warnings

1. Read and understand the entire owners manual before attempting assembly or operation.
2. Read and understand the warnings posted on the machine and in this manual. Failure to comply with all of these warnings may cause serious injury.
3. Replace the warning labels if they become obscured or removed.
4. This jointer is designed and intended for use by properly trained and experienced personnel only. If you are not familiar with the proper and safe operation of a jointer, do not use until proper training and knowledge have been obtained.
5. Do not use this jointer for other than its intended use.
6. Always wear approved safety glasses/face shields while using this jointer. Everyday eyeglasses only have impact resistant lenses; they are not safety glasses.
7. Before operating this jointer, remove tie, rings, watches and other jewelry, and roll sleeves up past the elbows. Remove all loose clothing and confine long hair. Non-slip footwear or anti-skid floor strips are recommended. Do **not** wear gloves.
8. Wear ear protectors (plugs or muffs) during extended periods of operation.
9. Some dust created by power sanding, sawing, grinding, drilling and other construction activities contains chemicals known to cause cancer, birth defects or other reproductive harm. Some examples of these chemicals are:
 - Lead from lead based paint.
 - Crystalline silica from bricks, cement and other masonry products.
 - Arsenic and chromium from chemically treated lumber.Your risk of exposure varies, depending on how often you do this type of work. To reduce your exposure to these chemicals, work in a well-ventilated area and work with approved safety equipment, such as face or dust masks that are specifically designed to filter out microscopic particles.
10. Do not operate this machine while tired or under the influence of drugs, alcohol or any medication.
11. Make certain the switch is in the **OFF** position before connecting the machine to the power supply.
12. Make certain the machine is properly grounded.
13. Make all machine adjustments or maintenance with the machine unplugged from the power source.
14. Remove adjusting keys and wrenches. Form a habit of checking to see that keys and adjusting wrenches are removed from the machine before turning it on.
15. Keep safety guards in place at all times when the machine is in use. If removed for maintenance purposes, use extreme caution and replace the guards immediately.
16. Make sure the jointer is firmly secured to the stand or a bench before use.
17. Check damaged parts. Before further use of the machine, a guard or other part that is damaged should be carefully checked to determine that it will operate properly and perform its intended function. Check for alignment of moving parts, binding of moving parts, breakage of parts, mounting and any other conditions that may affect its operation. A guard or other part that is damaged should be properly repaired or replaced.
18. Provide for adequate space surrounding work area and non-glare, overhead lighting.
19. Keep the floor around the machine clean and free of scrap material, oil and grease.
20. Keep visitors a safe distance from the work area. **Keep children away.**



Warnings

21. Make your workshop child proof with padlocks, master switches or by removing starter keys.
22. Give your work undivided attention. Looking around, carrying on a conversation and “horse-play” are careless acts that can result in serious injury.
23. Maintain a balanced stance at all times so that you do not fall or lean against the knives or other moving parts. Do not overreach or use excessive force to perform any machine operation.
24. Use the right tool at the correct speed and feed rate. Do not force a tool or attachment to do a job for which it was not designed. The right tool will do the job better and safer.
25. Use recommended accessories; improper accessories may be hazardous.
26. Maintain tools with care. Keep knives sharp and clean for the best and safest performance. Follow instructions for lubricating and changing accessories.
27. Turn off the machine and disconnect from power before cleaning. Use a brush or compressed air to remove chips or debris — do not use your hands.
28. Do not stand on the machine. Serious injury could occur if the machine tips over.
29. Never leave the machine running unattended. Turn the power off and do not leave the machine until it comes to a complete stop.
30. Remove loose items and unnecessary work pieces from the area before starting the machine.

Familiarize yourself with the following safety notices used in this manual:

CAUTION

This means that if precautions are not heeded, it may result in minor injury and/or possible machine damage.

WARNING

This means that if precautions are not heeded, it may result in serious injury or possibly even death.

Identification

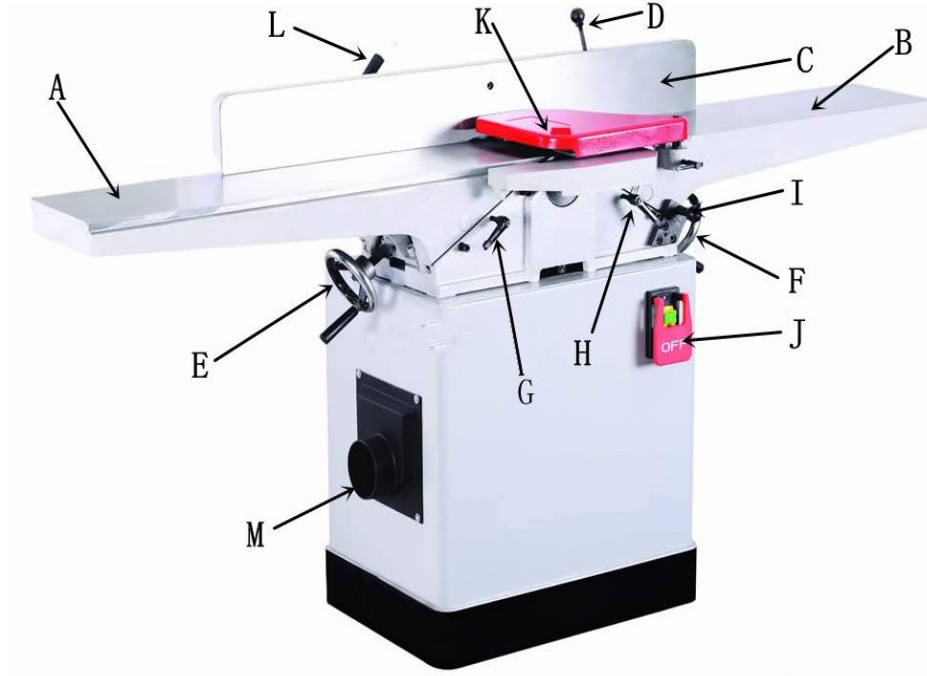

- | | |
|----------------------------|----------------------|
| A. Outfeed Table | H. Infeed Table Lock |
| B. Infeed Table | I. 1/8" Depth Stop |
| C. Fence | J. Magnetic Switch |
| D. Fence Tilt Handle | K. Cutterhead Guard |
| E. Outfeed Table Handwheel | L. Fence Lock |
| F. Infeed Table Handwheel | M. 4" Dust Port |
| G. Outfeed Table Lock | |

Specifications

Cutting Capacity.....	8"W x 1/2"D
Cutterhead Speed.....	5500 RPM
Number of Knives.....	4
Rabbeting Capacity.....	1/2"
Maximum depth of cut(per pass).....	1/8"
Table Surface.....	9"W x 71"L
Fence.....	4"W x 39-1/2"L
Knife Size.....	8"L x 11/16"W x 1/8"T
Fence Tilt.....	45°L, 45°R
Positive Stops.....	45°L, 90°, 45°R
Motor.....	2HP, TEFC Capacity Start Induction
Net Weight, Jointer and Stand (approx.).....	405 lbs
Shipping Weight, Jointer and Stand.....	458 lbs

Unpacking and Cleanup

Contents of Shipping Cartons

Note: Unit shipped in one crate and one carton.

Stand Carton(Not shown in picture)

- 1 Stand with Motor and Switch

Jointer Body Crate

Jointer-Body Assembly(Not shown)

- A Fence
- B Fence Carriage Assembly
- C Cutterhead Guard
- D Dust Chute
- E Belt Guard
- F Handwheels*2
- G Handwheel Handles*2
- H V-Belts*2
- I Knife Setting Jig
- J Fence Handle
- K Belt Guard Lock
- L Switch Emergency stop Paddle
- M Push Blocks*2

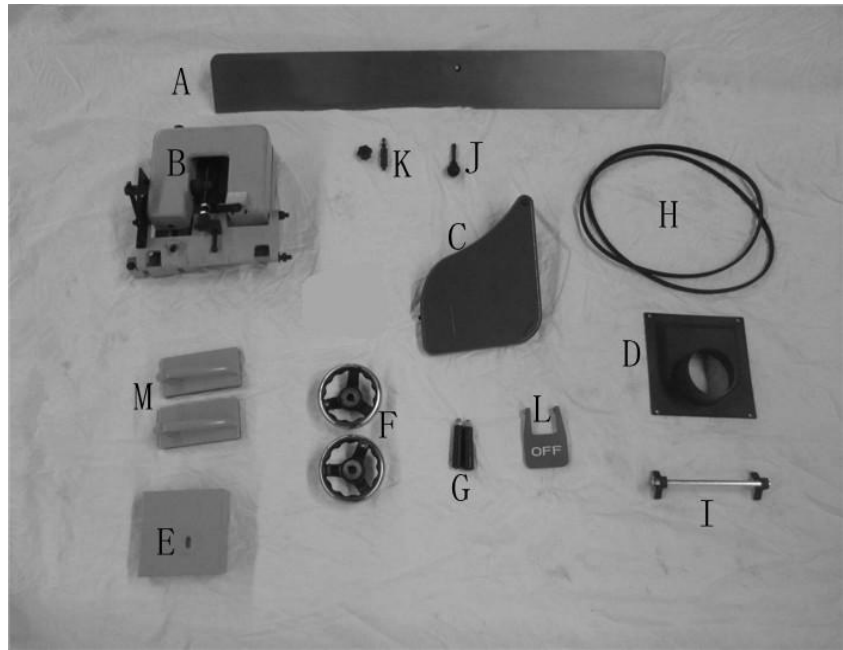

Jointer Body Crate Contents

Hardware Included

- 1 Jointer Mounting Bolts
- 1 10mm Lock Washer
- 3 10mm Flat Washer

Tools Included

- 1 12/14mm Open End Wrench
- 1 8/10mm Open End Wrench
- 4 Hex Wrenches (3, 4, 5, 8 mm)

Tools Required for Assembly:

- #1 Cross Point Screwdriver
- 6-8" Adjustable Wrench or 17 & 19mm Wrench

Unpacking and Cleanup

1. Carefully finish removing all contents from both shipping cartons. Compare contents of the shipping cartons with the list of contents above. Place parts on a protected surface.
2. Set packing material and shipping cartons to the side. Do not discard until machine has been set up and is running properly.
3. Clean all rust protected surfaces (bed, fence, etc.) with kerosene or diesel oil. Do not use gasoline, paint thinner, mineral spirits, etc. These may damage painted surfaces.



Hardware Included



Tools Included

⚠ WARNING Cutterhead knives are dangerously sharp! Use extreme caution when cleaning.

4. Apply a thin layer of paste wax to the bright surfaces of the fence and tables to prevent rust.



Figure 1

Installing Bed to Stand

1. Use an assistant or hoist mechanism to place bed assembly on top of stand.
2. Line up two holes in top of stand with holes in jointer body assembly (Fig. 1)
3. Attach bed assembly to stand with two 3/8" lock bolts and lock washers (Fig. 2). Hand tighten only at this time.
4. Line up third hole in stand with hole in bed assembly by viewing through dust chute.
5. Install third 3/8" lock bolt and lock washer through dust chute to secure bed to stand.
6. Tighten all three mounting bolts with 14mm wrench.

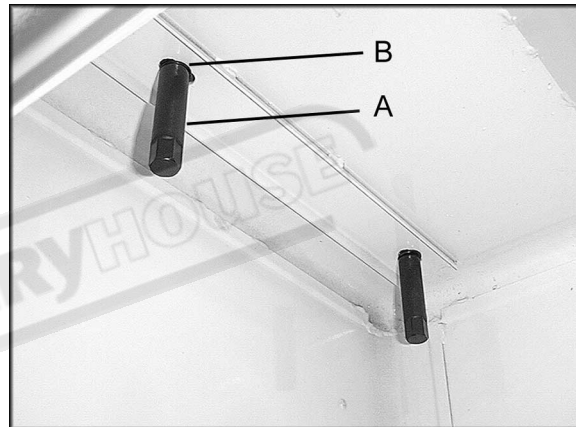

Figure 2

Installing Handwheels

1. Remove protective tape from shaft, and remove screw and washer.
2. Press handwheel (A, Fig. 3) onto shaft, aligning the keyway with the key. If necessary, use a hammer with a block of wood to tap the handwheel completely onto the shaft.
3. Re-install screw and washer (B, Fig. 3).
4. Mount handle (C, Fig. 3) onto handwheel.

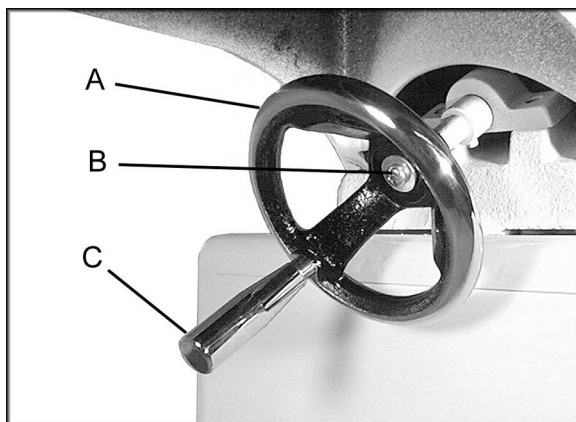

Figure 3

Installing Fence Carriage to Jointer

1. Loosen the two cap screws attached on the back of the jointer. Note-DO NOT completely remove the cap screws.
2. Use an man assistant to hold the fence carriage.
3. Line up two open holes on the fence carriage with the two cap screws. (Fig. 4)
4. Attach the fence carriage to jointer, make sure the surface of carriage level with jointer table surface, tighten the cap screws.

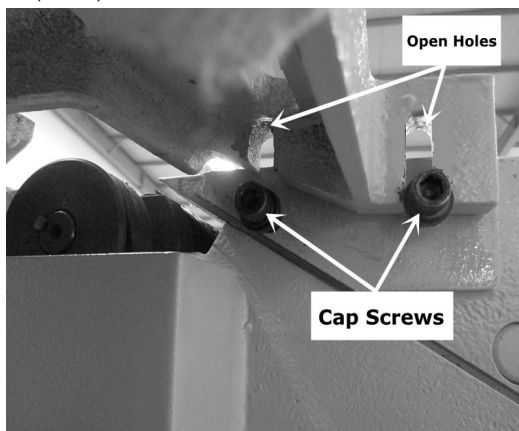

Figure 4

Installing Fence to Fence Carriage

1. Loosen and take off the cap screw attached on the fence holder.(Fig. 5)
2. Line up the hole on the fence and thread on fence holder.(Fig. 5)
3. Connect these two parts with the cap screw. And tighten it.
4. Loosen the two cone screws on the fence carriage (A Fig. 6), line up with the two cone nuts on the fence (B Fig. 6).
5. Tighten cone screws while adjusting the flexibility of the fence by tilting th fence. When the fence is secured and also properly flexibe, tighten the nut on cone screws(C Fig. 6).

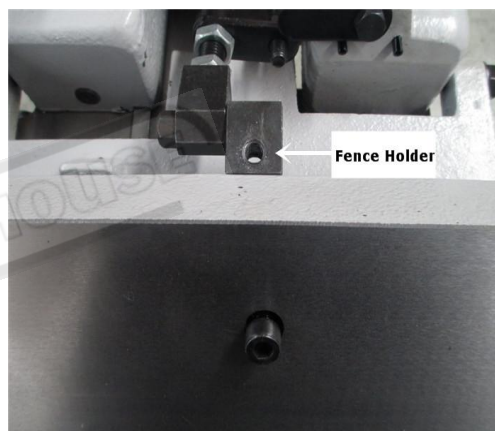

Figure 5

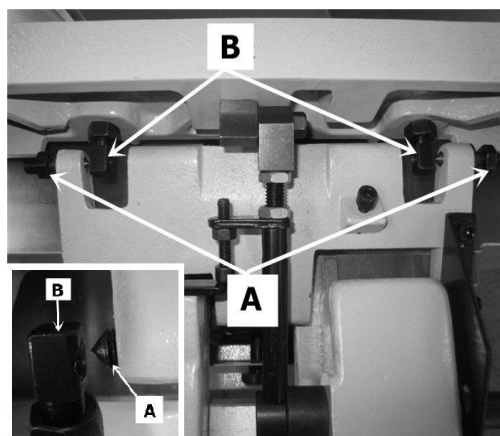

Figure 6

Installing V-Belts

1. Disconnect the machine from the power source, unplug.
2. Remove the lock knob (A, Fig. 4) and belt guard (B, Fig. 4).
3. Place v-belts onto cutterhead pulley grooves and through opening in stand.
4. In stand, loosen the motor mount bolts. Note-DO NOT completely remove the motor mount bolts.
5. Carefully allow the motor to slide downward place v-belt onto motor pulley grooves, tensioning the v-belt with the weight of the motor. (Fig. 5)
6. Check to make sure that motor pulley and cutterhead pulley are vertically aligned(Fig.5) the v-belt does not contact the sides of the opening in the base. If the pulleys are not aligned, loosen the bolts (A, Fig. 6) on the motor base and slide the motor until the belt is aligned. Re-tighten screws.
6. The v-belt is properly tensioned when finger pressure on the belt half way between the two pulleys causes 1/2" deflection. If the belt is too loose, loosen the motor mounting bolts (Fig. 5) on the mounting plate and push down on the plate. When belt tension is correct, re-tighten screws.
7. After two hours of operation, check belt tension again. Re-tension if necessary.
8. Re-install belt guard and lock knob.

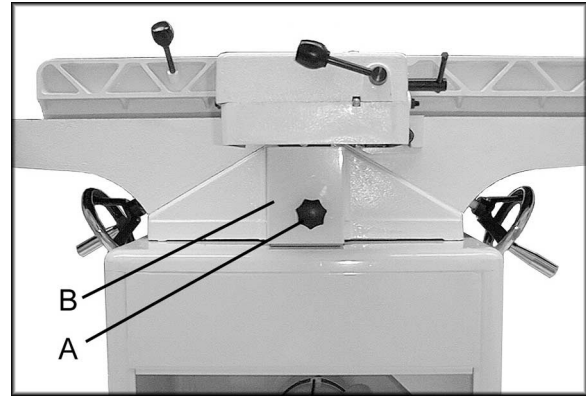

Figure 4

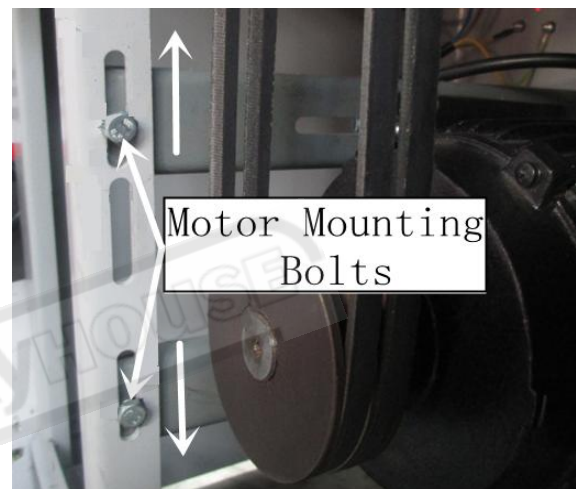

Figure 5

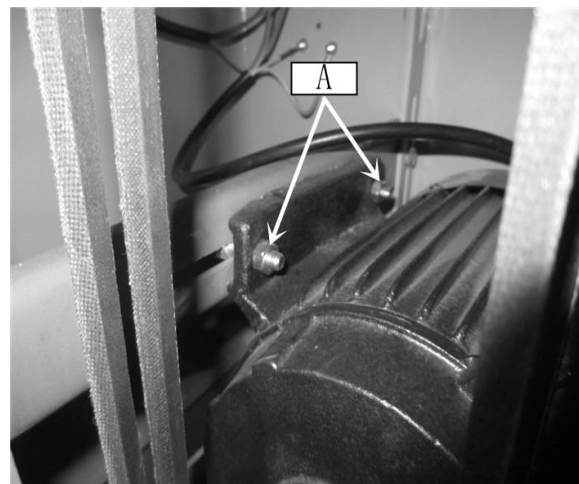

Figure 6

Installing Cutterhead Guard

1. Wind the tang the torsion spring back a half turn, and slide the guard shaft into the casting so the spring tang points to the right and reset against the casting.(Fig. 7)

2. Test the guard by pulling in back and letting go.

-The guard should snap back over the cutterhead without dragging across the table. If it does, tighten the shaft lock.

-If the guard drags across the table, raise it until it won't drag, then tighten the shaft lock.

-If the guard does not snap back, remove it and repeat STEP 1&2, increasing the spring tension as needed.

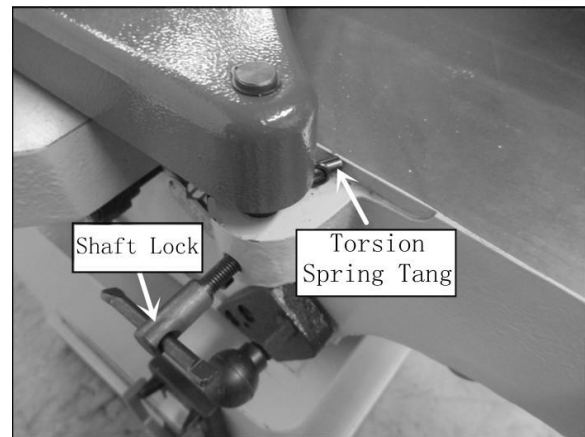

Figure 7

Installing Dust Chute

Attach the dust chute (Fig. 8) to the stand with four screws and four flat washers, through the pre-tapped holes in the stand.

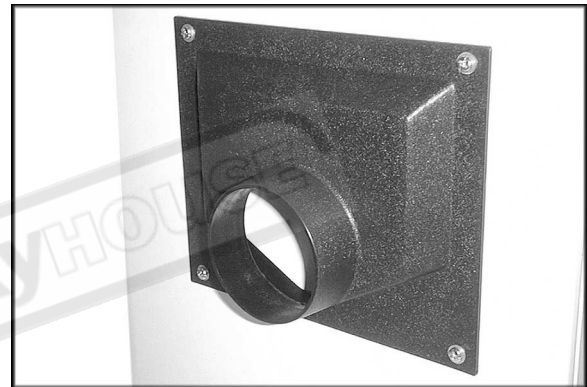

Figure 8

Setting Outfeed Table Height

⚠WARNING Machine should be disconnected from power source at this time! Cutterhead blades are extremely sharp! Use caution when hands are near the cutterhead!

For most jointing operations, the surface of the outfeed table must be level with the knife tips of the cutterhead at their highest point of revolution. The knife tips must project equally from the cutterhead.

The outfeed table and cutterhead are adjusted at the factory and should not require adjustment. However, it may change during the shipment, check the outfeed table height before use, if it is changed, reset the outfeed table height as following:

1. Place a straightedge(C Fig. 9) on the out-table so it extends over the cutterhead.

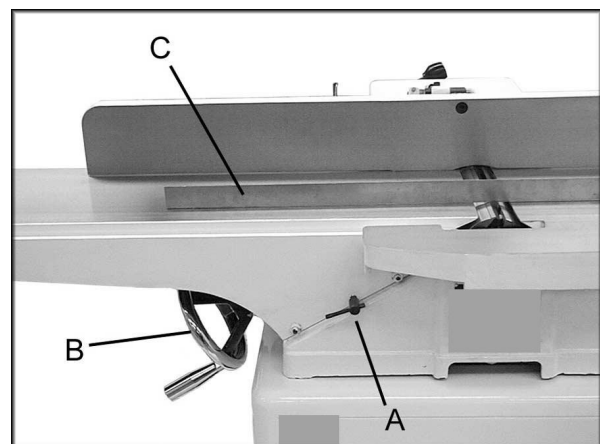

Figure 9

2. Rotate the cutterhead by turning the cutterhead pulley until one of the knives is at top-dead-center(TDC), as shown in Fig.10
3. Loosen table lock screw (A, Fig. 9) and raise the outfeed table to the height of blade number one by turning handwheel (B, Fig. 9). Counter-clockwise will cause the outfeed table to raise. Clockwise will cause the outfeed table to lower. Set a straight edge (C, Fig. 9) on the outfeed table and across the cutterhead.

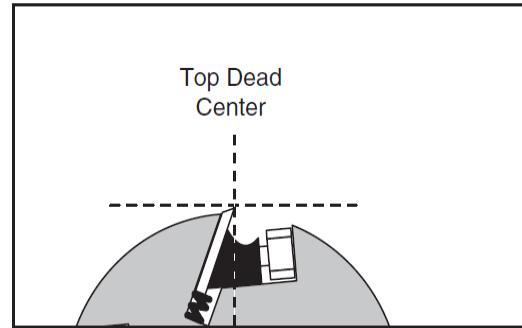

Figure 10

4. Position of the table and straight edge should look like Figure 11. Use care when handling the straight edge near the blades so as not to damage them.
5. When the outfeed table and blade number one (or knife insert) are the same height, tighten table lock screw.

After the outfeed table has been set, it will need no further adjustments to the cutterhead – skip steps 6 through 9 below. It must have its knives parallel with the outfeed table. Proceed as follows:

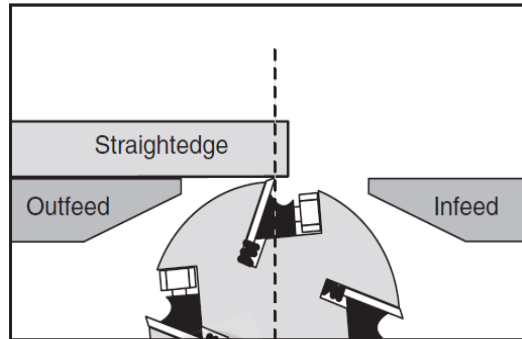

Figure 11

6. Bring the straight edge forward to the front of the outfeed table and confirm that blade is at the same height at the front of the table as it is at the back of the table.
7. If blade is higher or lower at one point, Loosen cutterhead gib bolt (A, Fig. 12) by turning clockwise as viewed from the infeed table.
8. Place the knife setting gauge (B, Fig. 12) on the cutterhead over the blade. Find the jack screws through the access holes in the cutterhead(Fig. 13) and rotate the jack screws to raise or lower the knife. When the knife is set correctly, it will barely touch the middle pad of the knife setting jog. Snug the gib bolts tight enough to just hold the knife in place. Repeat STEP 7&8 with the rest of the knives.

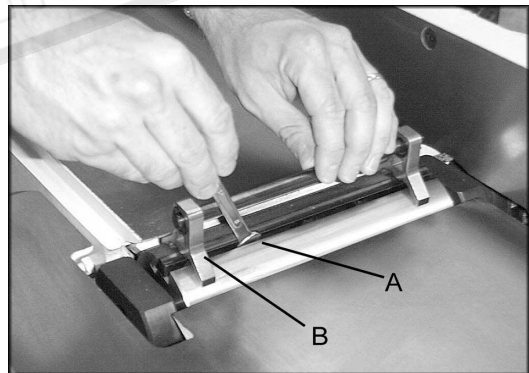

Figure 12

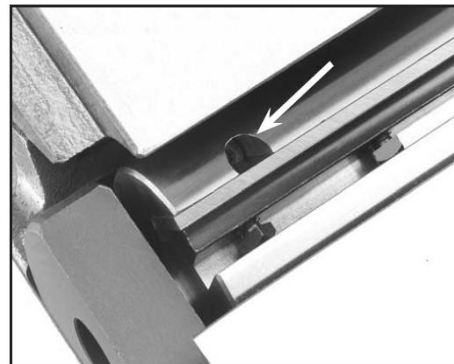

Figure 13

Adjustments

To Set The 90° Fence Stop

Note: whenever making an adjustment to the fence, lift the fence up slightly after releasing the lock handle to avoid scratching the table.

1. Using a 90° square, adjust the fence to the 90° position, as shown in Fig. 14
2. Flip the 90° swing stop into the position shown in Fig. 15
3. Loosen the jam nut on the 90° fence stop bolt Fig. 15
4. Adjust the 90° fence stop bolt until it makes contact with the 90° swing stop.
5. Retighten the jam nut loosened in STEP 3.

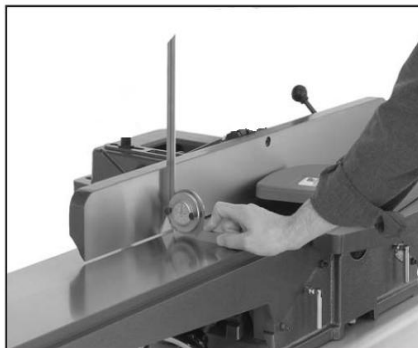

Figure 14

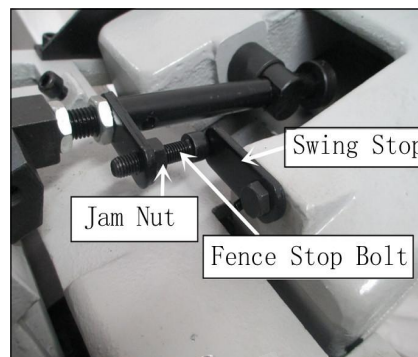

Figure 15

To Set the 45° Inward Fence Stop

Note: Whenever making an adjustment to the fence, lift the fence up slightly after releasing the lock handle to avoid scratching the table.

1. Using a 45° square, adjust the fence to the 45° inward position, as shown in Fig. 16
2. Loosen the set screw on fence stop block as shown in Fig. 17
3. Adjust the fence stop block until it makes contact with the back of the fence bracket.
4. Retighten the set screw on the fence stop stop block loosened in STEP 2

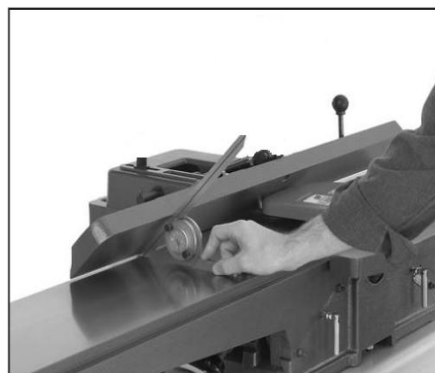

Figure 16

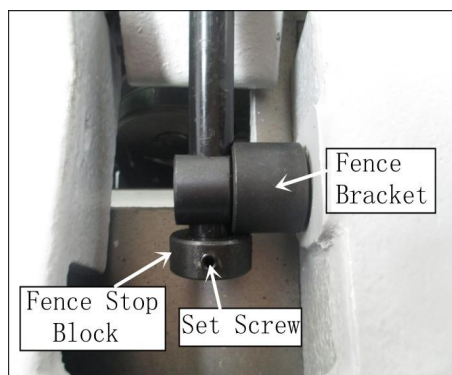

Figure 17

To Set the 45° Outward Fence Stop

Note: Whenever making an adjustment to the fence, lift the fence up slightly after releasing the lock handle to avoid scratching the table.

1. Using a sliding bevel adjusted to 135°, adjust the fence to the 135° (45° inward) position as shown in Fig. 18
2. Adjust the 45° outward fence stop set screw until it makes contact with the back of the fence as shown in Fig. 19

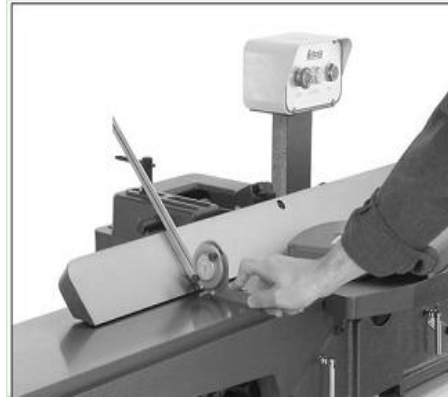

Figure 18

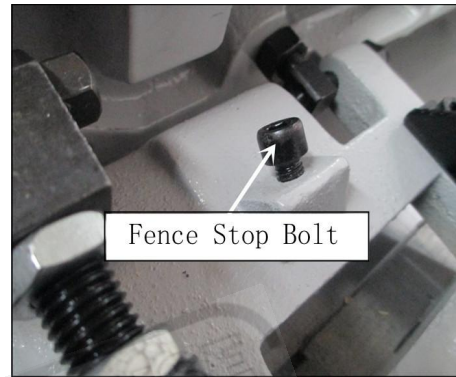

Figure 19

Gib Adjustment

After a period of use, the gibs may become loose and need adjusting:

1. Loosen two lock nuts and gib lock screws. As shown in Fig. 20
2. Tighten each set screw 1/4 turn starting at the bottom and working up. If a 1/4 turn does not remove all play, take another 1/4 turn. Repeat a 1/4 turn at a time for all three set screws until play is removed.
3. Tighten lock screws and lock nuts

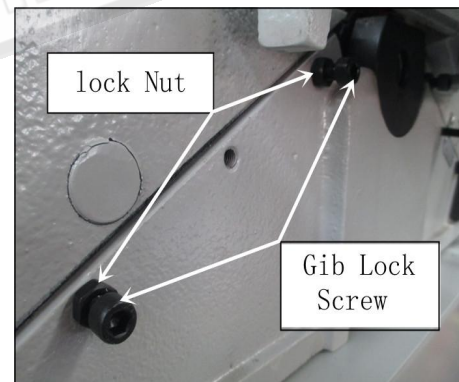

Figure 20

Removing and Replacing Knives (Stright Knife Cutterhead Only)

⚠WARNING Disconnect the machine from the power source before making any adjustment or repair. All knife lock bolts must be firmly tightened or risk ejection of the knife(s) and lock bar from the cutterhead! Failure to comply may cause serious injury!

1. Disconnect machine from power source.
2. Remove blade guard.
Caution: blades are sharp! Use great care when hands are around blade area!
3. Loosen the lock screws (Fig. 21). Note: Loosen screws by turning in a clockwise direction as viewed from the infeed table. Carefully remove the knife (A, Fig. 22), and the lock bar with screws (B, Fig. 22). Repeat for the other two blades.
4. Before assembly, clean all parts thoroughly and clear cutterhead knife slots of any dust or debris.
5. Insert knife into the cutterhead channel making sure it faces the proper direction.
6. Insert lock bar and screws and tighten to hold in place. Blades are set at the proper height when the top of the blade is 1/16" above the cutterhead.
7. Repeat for other two blades.
8. To set the knives to the outfeed table and to the same height in the cutterhead, see section titled "Leveling Outfeed Table to Cutterhead Knives" found on page 10 of this manual.

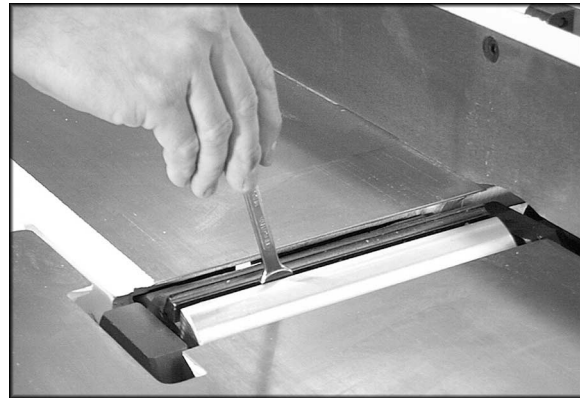

Figure 21

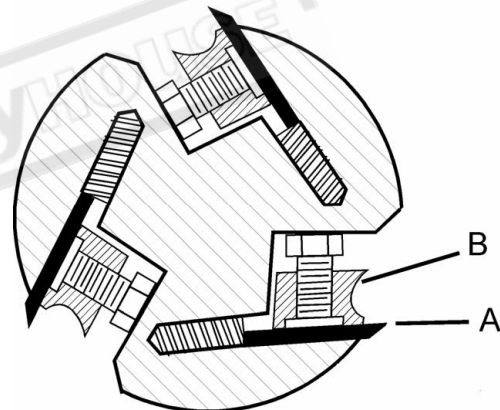

Figure 22

Replacing or Rotating Knife Inserts (Spiral Cutterhead Only)

The knife inserts on the Spiral Cutterhead Jinter are four-sided. When dull, simply remove each insert, rotate it 90° for a fresh edge, and re-install it.

Use the two provided star point screwdrivers to remove the knife insert screw. See Figure 23. Use one of the screwdrivers to help hold the cutterhead in position, and the other to remove the screw. It is advisable to rotate all inserts at the same time to maintain consistent cutting. However, if one or more knife inserts develops a nick, rotate only those inserts that are affected.

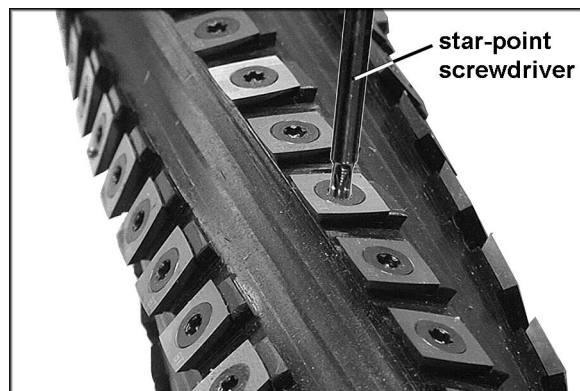

Figure 23

Each knife insert has an etched reference mark so that you can keep track of the rotations.

IMPORTANT: When removing or rotating inserts, clean saw dust from the screw, the insert, and the cutterhead platform. Dust accumulation between these elements can prevent the insert from seating properly, and may affect the quality of the cut.

Before installing each screw, lightly coat the screw threads with machine oil and wipe off any excess.

Securely tighten each screw which holds the knife inserts before operating the planer!

⚠WARNING Make sure all knife insert screws are tightened securely. Loose inserts can be propelled at high speed from a rotating cutterhead, causing injury.

Operation

⚠WARNING Keep all guards in place and in adjustment at all times during the cutting procedure! Keep hands away from the cutterhead! Do not pass hands directly over the cutterhead! The use of push sticks and/or handle pads are highly recommended when using the jointer! Failure to comply may cause serious injury!

Jointing cuts or edge jointing are made to square an edge of a workpiece. The workpiece is positioned on the jointer with the narrow edge of the workpiece on the infeed table and the major flat surface of the workpiece against the fence (Fig. 24).

Planing cuts are similar. The major surface of the workpiece is placed on the table with the narrow edge of the workpiece against the fence (Fig. 25).

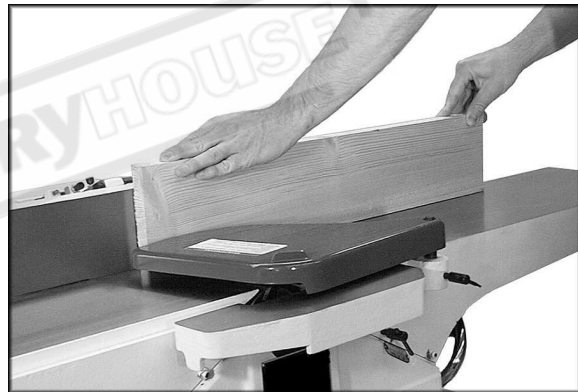

Figure 24



Figure 25

For jointing and planing cuts pressure is directed three ways; into the fence to ensure a square cut, forward to advance the stock, and downward to avoid chatter and vibration.

For jointing when the material is higher than the fence, the left hand applies pressure into the fence and down toward the table while the right hand pushes forward from behind. Be sure to keep the right hand high up on the material. (Fig. 24)

For jointing material that is lower than the fence, use push sticks to protect the hands. For planing, use push blocks. (Fig. 25) **Never place the right hand on the trailing edge of the material. Hand placement on the trailing edge of the material may cause the hand to come into contact with the blade.**

Feed work from right to left at a steady, moderate speed. If you feed the material too slowly, the wood will burn in places. If you feed the material too quickly, ridges will appear in the finished surface.

Jointing Warped Material

If the work to be jointed is cupped or warped, take light, repetitive cuts until the surface is flat. Forcing the material flat against the table will still leave a warped piece after the cuts have been made.

⚠WARNING Never joint any material shorter than eight inches! The material may tip into the jointer's throat and be kicked back! Avoid jointing thin material which could become jammed under the fence or blade guard! Failure to comply may cause serious injury!

Direction of Grain

Feed the material with of the grain to avoid tearout (Fig. 26). If the direction of the grain changes somewhere in the board, try reducing depth of cut and slow the feed speed down to avoid tearout. If results still aren't satisfactory, turn the material around and try feeding through the other way.

Bevel Cut

To cut a bevel, lock the fence at the desired angle and run the material through, pressing the work firmly against the fence and tables (Fig. 27). Several passes may be necessary for the desired result.

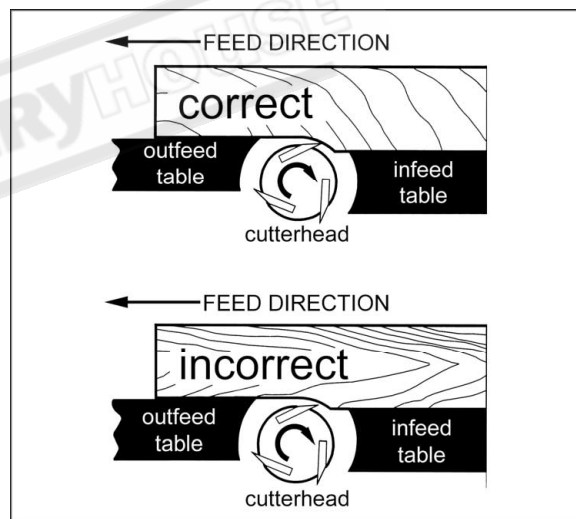

Figure 26



Figure 27

Taper Cut

⚠WARNING Taper cuts require the removal of the cutterhead guard. Use extreme caution when making taper cuts and replace the guard immediately after completion! Failure to comply may cause serious injury!

One of the most useful jointer operations is cutting an edge to a taper. This method can be used on a wide variety of work; tapered legs of furniture is a common example.

Instead of laying the piece down on the infeed table, lower the forward end of the work onto the outfeed table. Use caution, however, as the piece will span the knives, and they will take a "bite" from the work with a tendency to kick back unless the piece is held firmly. Push the work forward as in ordinary jointing. The effect is to plane off all the stock in front of the knives to an increasing depth, leaving a tapered surface.

The ridge left by the knives when starting the taper may be removed by taking a very light cut in the regular jointing procedure, with the infeed table raised to its normal position.

Practice is required in this operation. Beginners are advised to make trial cuts with scrap material.

Rabbet Cut

⚠WARNING Rabbeting requires the removal of the cutterhead guard. Use extreme caution when making rabbeting cuts and replace the guard immediately after completion! Failure to comply may cause serious injury!

Note: Rabbet cuts are not applicable with the Model JJ-8HH Jointer with helical head.

1. Adjust the fence so that the distance between the end of the knives and fence is equal to the width of the rabbet (Fig. 28).
2. Lower the infeed table an amount equal to the depth of the rabbet. If the rabbet is quite deep, it may be necessary to cut in two or more passes.
3. In that event, the table is lowered an amount equal to about half the depth of the rabbet for the first pass, then lowered again to proper depth to complete the cut.

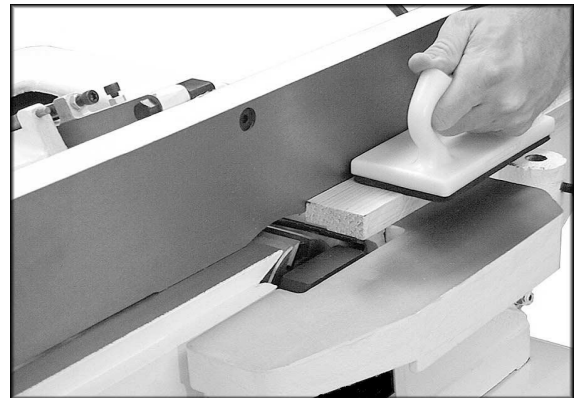

Figure 28

Maintenance

Lubrication

1. Use a good grade of light grease on the steel adjusting screws located in the raising and lowering mechanisms of the work tables.
2. Occasionally, apply a few drops of light machine oil to the gibs. This permits the tables to slide freely.
3. The cutterhead ball bearings are lifetime lubricated and need no further care.

Blade Care

▲WARNING Blades are extremely sharp! Use caution when cleaning or changing. Failure to comply may cause serious injury!

When gum and pitch collect on the blades, carefully remove with a strong solvent. Failure to remove gum and pitch build-up may result in excessive friction and overheating.

Sharpening the Stright Knives

When blades become dull, touch up blades.

1. Disconnect the machine from the power source.
2. Remove the fence, blade guard and belt cover.
3. To protect the infeed table from scratches, partially cover the sharpening stone with paper. (Fig. 29)

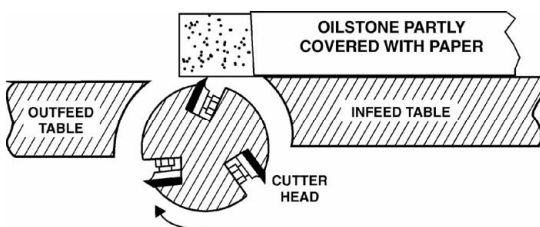

Figure 29

4. Lay the stone on the infeed table.
5. Lower the infeed table and turn the cutterhead by turning the cutterhead pulley. The infeed table height is set properly when the stone's surface is flush with the knife bevel.
6. Keep the cutterhead from rotating by grasping the cutterhead pulley while sliding the stone back and forth across the table.

7. Take the same amount of passes for all three blades.

When the blades have been sharpened, if they still are not cutting efficiently, trying to touch up the blades further will only cause the formation of a second beveled edge. When this starts to happen, it is time to replace blades with another set.

It is recommended to keep a second set of blades on hand so that they may be installed while the first set is being professionally sharpened.

Cutterhead Removal

▲WARNING Blades in the cutterhead are sharp! Use extreme caution when handling the removal of the cutterhead. Failure to comply may cause serious injury!

The entire cutterhead assembly may be removed for cleaning or for bearing and blade replacement. Some woodworkers keep a spare cutterhead with replacement blades should the original cutterhead have to be repaired.

To remove the cutterhead (including bearings, studs, and housing) from the base casting:

1. Disconnect the machine from the power source.
2. Remove the fence assembly, cutterhead guard, and belt guard.
3. Remove the v-belt from the cutterhead pulley.
4. Loosen set screw (A, Fig. 30) using a hex wrench and remove the cutterhead pulley (B, Fig. 30) and key (C, Fig. 30).
5. Remove nuts (D, Fig. 30) and lock washers (E, Fig. 30).

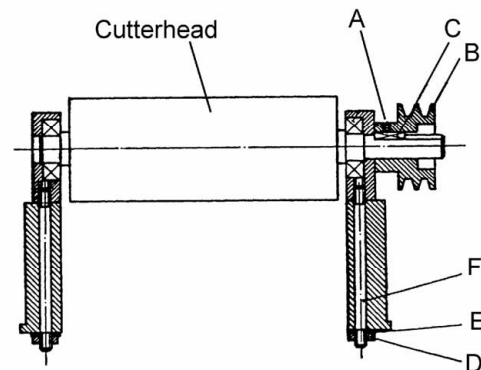

Figure 30

6. Lift assembly straight up. Studs (F, Fig. 30) will still be attached to the bearing housings.
7. Before replacing the cutterhead back into the casting, thoroughly clean the "saddle" and the bearing housings of saw dust and grease so that they seat properly.
8. To re-install the cutterhead, reverse the above steps.

Troubleshooting

Trouble	Probable Cause	Remedy
Finished stock is concave on the end.	Knife tip is higher than outfeed table.	Raise outfeed table so it is level with knife tip.
Back side of finished stock is thicker than the front side.	Outfeed table is higher than knife tip.	Adjust outfeed table so it is level with knife tip.
Stock is concave in the middle.	Table flatness should be checked with a machinist's square.	Adjust the screws below the table to raise the table ends.
Both ends of finished stock are cut deeper than the middle.	Ends of tables are higher than middle.	Raise table ends with adjustment screws below tables.
Infeed or outfeed tables are loose.	Loose gib.	Tighten gibs.
Ripples on planed surface. Kickbacks	One blade set higher than the others.	Readjust blades
	Feeding wood too fast.	Feed wood more slowly.
	Cutting blades are set too high above outfeed table, or they may not be level with outfeed table. (Stright Knife)	Readjust blades (Stright Knife).
Excessive motor noise.	Motor	Have motor checked by a qualified repair station.
	Pulley set screw is loose.	Tighten set screw.
Motor fails to develop full power or stalls.	Circuit overloaded with lights, tools, etc.	Do not share the circuit.
	Undersize wires or circuit too long.	Increase wire sizes, or reduce length of wiring.
	Voltage too low.	Request voltage check from the power company.
	Fuses or circuit breakers do not have sufficient capacity.	Have a qualified electrician install proper size fuses or circuit breakers.
Motor starts slowly or fails to come to full speed.	Motor	Have motor checked by a qualified repair station.
	Belt tension too tight.	Adjust belt tension.
	Bad start capacitor.	Replace start capacitor.

SPARE PARTS SECTION

The following section covers the spare parts diagrams and lists that were current at the time this manual was originally printed. Due to continuous improvements of the machine, changes may be made at any time without notification.

HOW TO ORDER SPARE PARTS

1. Have your machines **model number, serial number & date of manufacture** on hand, these can be found on the specification plate mounted on the machine
2. A scanned copy of your parts list/diagram with required spare part/s identified
3. Go to www.machineryhouse.com.au/contactus and fill out the enquiry form attaching a copy of scanned parts list.

CONTENTS

Table-----	21
Cutter Head -----	22
Fence-----	23
Base-----	24
Risk Assesment-----	25

Table

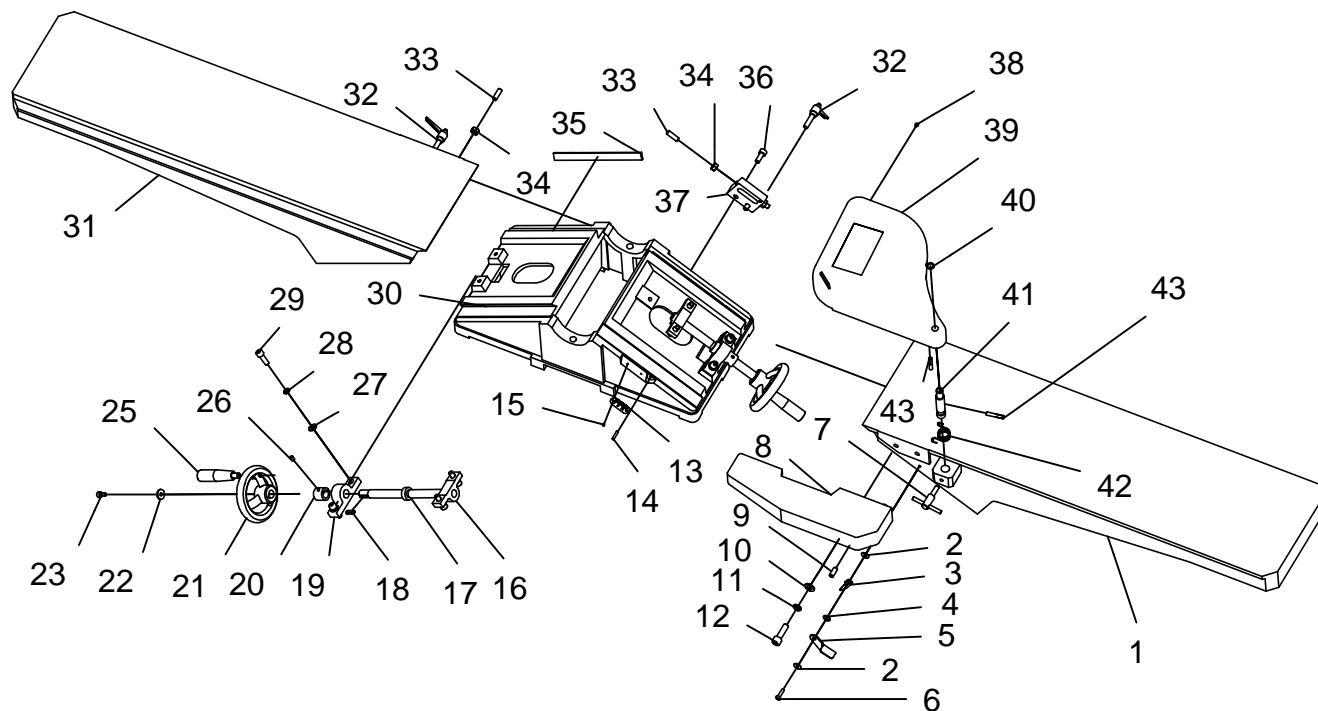

PART	DESCRIPTION	QTY	PART	DESCRIPTION	QTY
1	INFEED TABLE	1	22	FLAT WASHER $\phi 6$	2
2	FENDER WASHER $\phi 5$	2	23	CAP SCREW M6*12	2
3	POINTER	1	25	HANDLE	2
4	SPECIAL WASHER	1	26	SET SCREW M6*8	4
5	1/8 PLATE	1	27	FLAT WASHER $\phi 8$	8
6	PH HEAD SCREW M5*16	1	28	LOCK WASHER $\phi 8$	8
7	LOCK SCREW	1	29	CAP SCREW M8*25	8
8	RABBET ARM	1	30	BASE	1
9	SET SCREW M8*20	1	31	OUTFEED TABLE	1
10	FLAT WASHER $\phi 10$	2	32	KNOB M6*30	2
11	LOCK WASHER $\phi 10$	2	33	SET SCREW M8*25	7
12	SCREW M10*35	2	34	NUT M8	8
13	SCALE	1	35	GIB	2
14	PIN $\phi 4*20$	1	36	CAP SCREW M8*20	2
15	RIVET 2*6	2	37	BLOCK	1
16	TABLE ADJUST NUT	2	38	RUBBER WASHER	1
17	HAND WHEEL SHAFT	2	39	CUTTERHEAD GUARD	1
18	KEY 5*20	2	40	RING $\phi 12$	1
19	BRACKET	2	41	GUARD PIVOT SHAFT	1
20	RING	2	42	SPRING	1
21	HANDWHEEL	2	43	ROLL PIN 6*40	2

Cutterhead

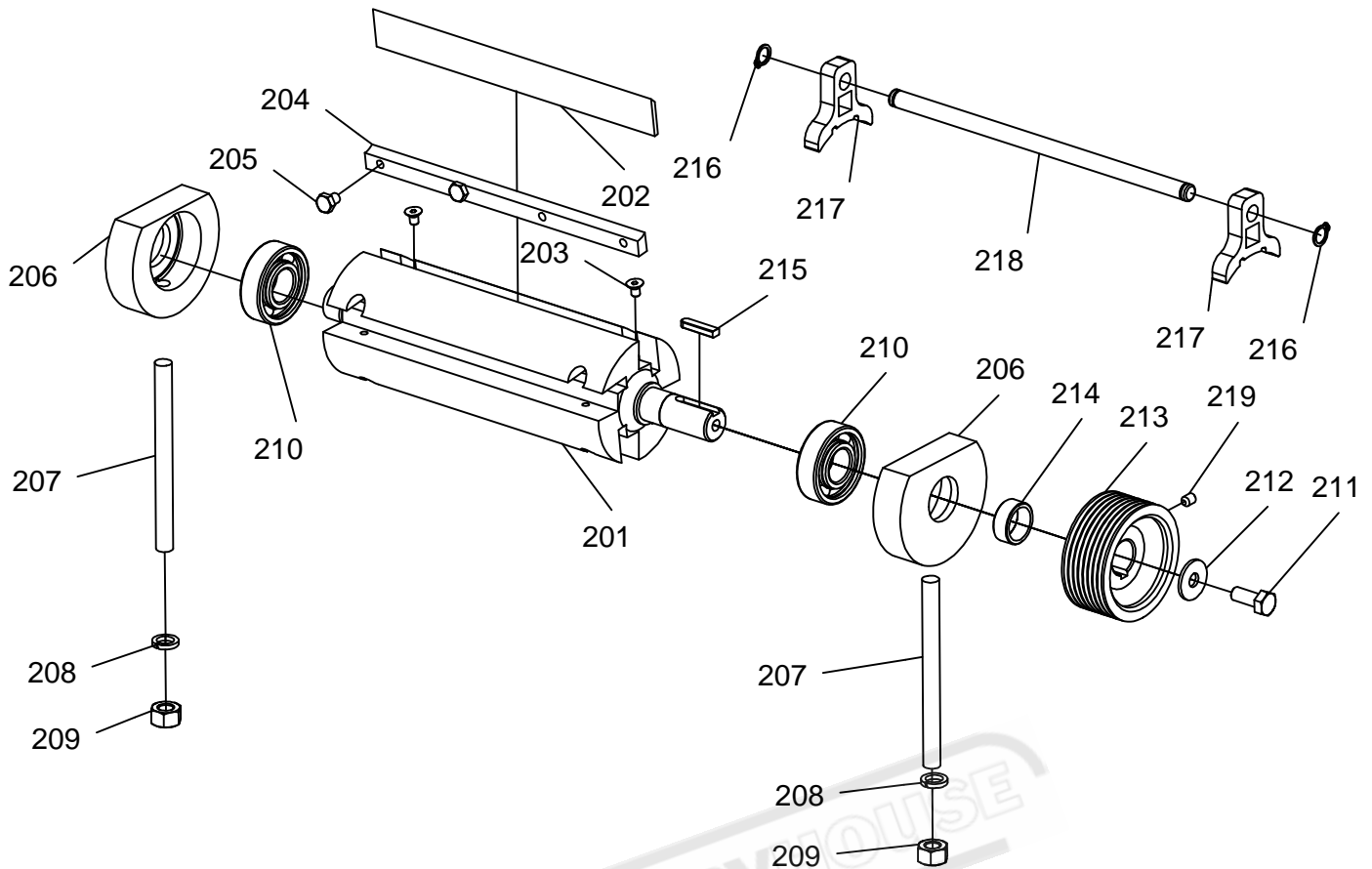

PART	DESCRIPCION	QTY
201	CUTER HEAD	1
202	KNIFE	4
203	FLAT CAP SCREW M5*12	8
204	GIB	4
205	GIB BOLT M6*10	16
206	BEARING BLOCK	2
207	STUD	2
208	LOCK WASHER 10	2
209	HEX NUT M10	2
210	BALL BEARING 6204	2
211	HEX BOLT M8*20	1
212	FLAT WASHER $\Phi 8 \times 28$	1
213	CUTTERHEAD PULLEY	1
214	COLLAR	1
215	KEY 6*25	1
216	EXT RET RING 10	2
217	KNIFE GAUGE BAR	2
218	KNIFE GAUGE SHAFT	1
219	SET SCREW M6*8	1

FENCE

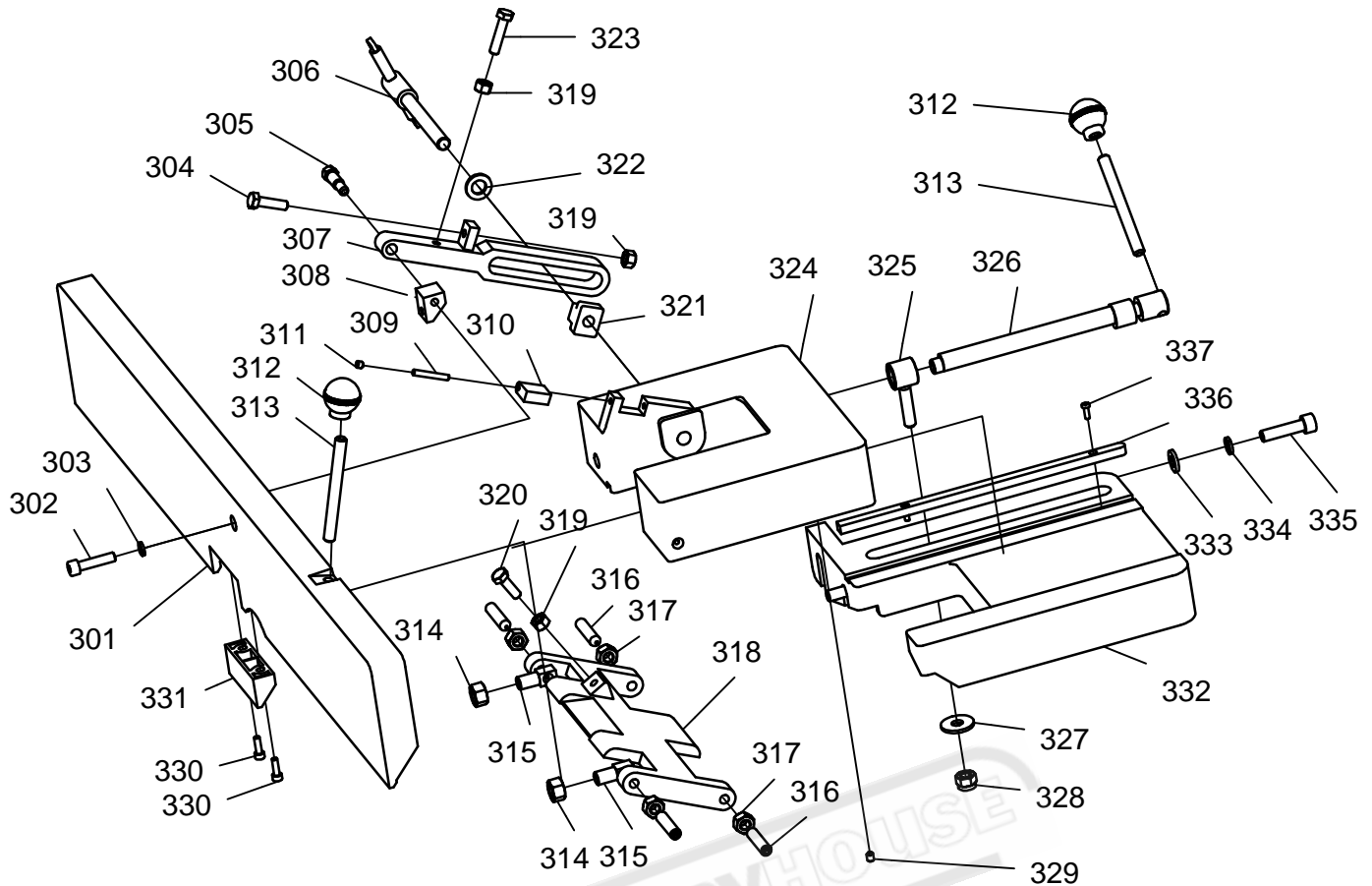

PART	DESCRIPTION	QTY	PART	DESCRIPTION	QTY
301	FENCE	1	320	HEX BOLT M8x25	1
302	CAP SCREW M8*35	1	321	LOCK NUT	1
303	LOCK WASHER 8	1	322	WASHER 12	1
304	HEX BOLT M8*30	1	323	HEX BOLT M8*35	1
305	SPECIAL SCREW	1	324	FENCE CARRIAGE	1
306	TILT LOCK SHAFT	1	325	ADJUST LEVER	1
307	CLAMP ARM	1	326	ENCENTRIC LOCK LEVER	1
308	BRACKET BLOCK	1	327	BIG WASHER 10	1
309	DOWEL PIN 5*35	1	328	LOCK HEX NUT M10	1
310	90 DEG STOP BLOCK	1	329	SET SCREW M6*8	1
311	SET SCREW M6*6	1	330	CAP SCREW M5*16	2
312	KNOB M10	2	331	FENCE GUIDE BLOCK	1
313	STUD M10	2	332	FENCE SUPPORT	1
314	HEX NUT M12*1	2	333	WASHER 10	2
315	SCREW BLOCK	2	334	LOCK WASHER 10	2
316	SET SCREW M10*45	4	335	CAP SCREW M10*40	2
317	HEX NUT M10	4	336	KEY 10*274	1
318	BRACKET	1	337	PH HE SCREW M4*12	2
319	HEX NUT M8	3			

Base

PART	DESCRIPTION	QTY	PART	DESCRIPTION	QTY
401	STAND	1	428	RUBBER FOOT M8*16	4
402	DUST PORT	1	431	PH HEAD SCREW M5*10	4
403	HEX NUT M8	12	432	FENDER WASHER 5	4
404	LOCK WASHER 8	8	433	HEX NUT M5	2
405	FLAT WASHER 8	4	434	LOCK WASHER 5	2
406	MOTOR	1	435	FLAT WASHER 5	2
407	KEY 8*40	1	436	SERRATED SPACER 5	2
408	BELT PK1180	1	437	SWITCH BOX	1
409	SET SCREW M6*8	2	438	HEX NUT M4	2
410	MOTOR PULLEY	1	439	STAIN RELIEF M20*1.5	3
411	PH HEAD SCREW M6*10	6	440	BELT COVER	1
412	BACK COVER	1	441	FANGE BOLT M6*12	2
413	CARRIAGE BOLT M8*25	4	442	PH HEAD SCREW M5*12	2
414	FENDER WASHER 8	8	443	PH HEAD SCREW M4*16	2
415	HEX BOLT M8*30	4	444	SWITCH	1
416	MOTOR MOUNT PLATE	2	445	BOLT M10	3
417	POWER CORD	1	446	LOCK WASHER 10	3
418	MOTOR CORD	1	447	FLAT WASHER 10	3

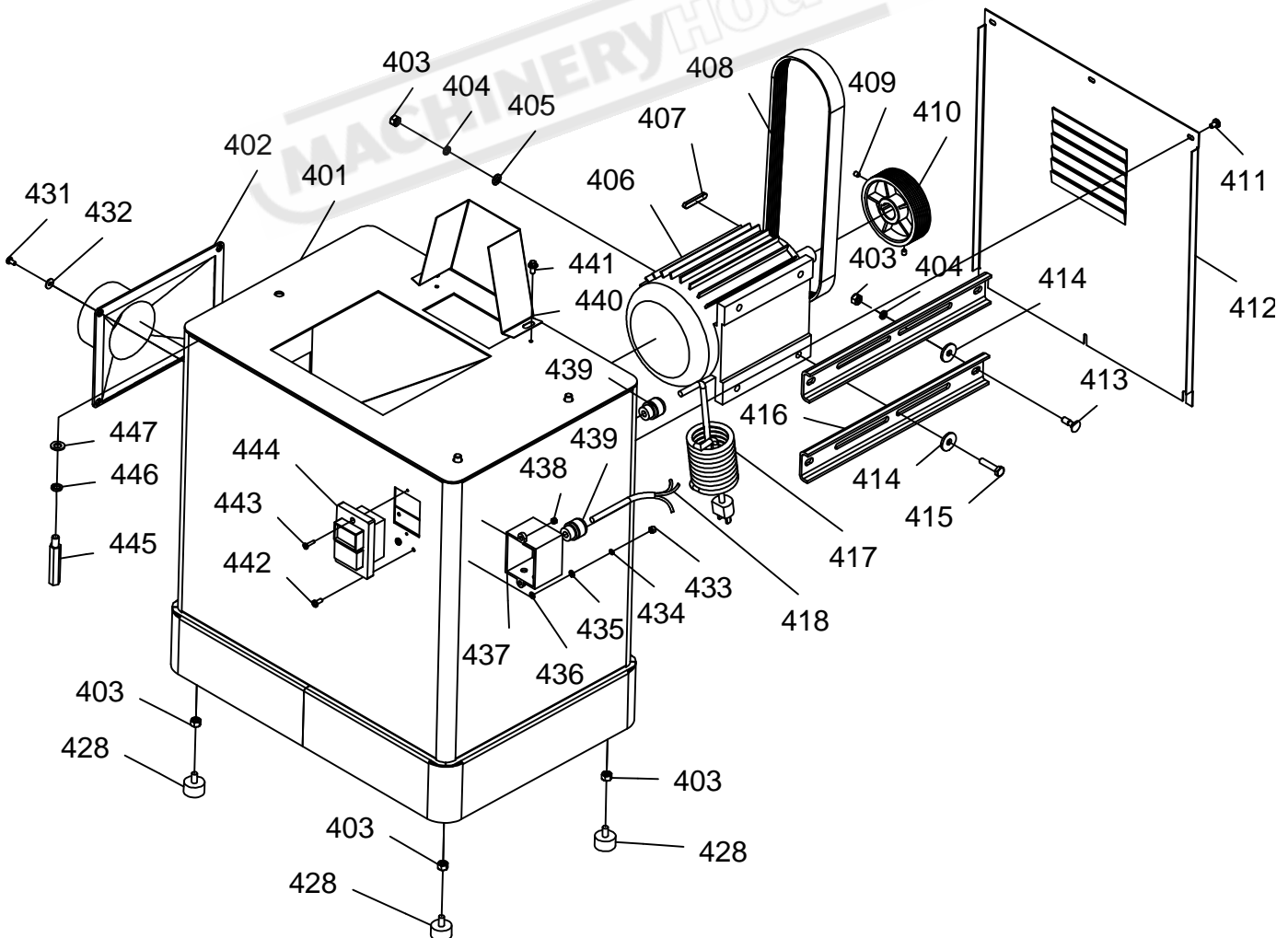



WARNING

General Machinery Safety Instructions

Machinery House
requires you to read this entire Manual before using this machine.

- 1. Read the entire Manual before starting machinery.** Machinery may cause serious injury if not correctly used.
- 2. Always use correct hearing protection when operating machinery.** Machinery noise may cause permanent hearing damage.
- 3. Machinery must never be used when tired, or under the influence of drugs or alcohol.** When running machinery you must be alert at all times.
- 4. Wear correct Clothing.** At all times remove all loose clothing, necklaces, rings, jewelry, etc. Long hair must be contained in a hair net. Non-slip protective footwear must be worn.
- 5. Always wear correct respirators around fumes or dust when operating machinery.** Machinery fumes & dust can cause serious respiratory illness. Dust extractors must be used where applicable.
- 6. Always wear correct safety glasses.** When machining you must use the correct eye protection to prevent injuring your eyes.
- 7. Keep work clean and make sure you have good lighting.** Cluttered and dark shadows may cause accidents.
- 8. Personnel must be properly trained or well supervised when operating machinery.** Make sure you have clear and safe understanding of the machine you are operating.
- 9. Keep children and visitors away.** Make sure children and visitors are at a safe distance for you work area.
- 10. Keep your workshop childproof.** Use padlocks, Turn off master power switches and remove start switch keys.
- 11. Never leave machine unattended.** Turn power off and wait till machine has come to a complete stop before leaving the machine unattended.
- 12. Make a safe working environment.** Do not use machine in a damp, wet area, or where flammable or noxious fumes may exist.
- 13. Disconnect main power before service machine.** Make sure power switch is in the off position before re-connecting.
- 14. Use correct amperage extension cords.** Undersized extension cords overheat and lose power. Replace extension cords if they become damaged.
- 15. Keep machine well maintained.** Keep blades sharp and clean for best and safest performance. Follow instructions when lubricating and changing accessories.
- 16. Keep machine well guarded.** Make sure guards on machine are in place and are all working correctly.
- 17. Do not overreach.** Keep proper footing and balance at all times.
- 18. Secure workpiece.** Use clamps or a vice to hold the workpiece where practical. Keeping the workpiece secure will free up your hand to operate the machine and will protect hand from injury.
- 19. Check machine over before operating.** Check machine for damaged parts, loose bolts, Keys and wrenches left on machine and any other conditions that may effect the machines operation. Repair and replace damaged parts.
- 20. Use recommended accessories.** Refer to instruction manual or ask correct service officer when using accessories. The use of improper accessories may cause the risk of injury.
- 21. Do not force machinery.** Work at the speed and capacity at which the machine or accessory was designed.
- 22. Use correct lifting practice.** Always use the correct lifting methods when using machinery. Incorrect lifting methods can cause serious injury.
- 23. Lock mobile bases.** Make sure any mobile bases are locked before using machine.
- 24. Allergic reactions.** Certain metal shavings and cutting fluids may cause an allergic reaction in people and animals, especially when cutting as the fumes can be inhaled. Make sure you know what type of metal and cutting fluid you will be exposed to and how to avoid contamination.
- 25. Call for help.** If at any time you experience difficulties, stop the machine and call you nearest branch service department for help.



WARNING

Planer-Jointer Safety Instructions

Machinery House
requires you to read this entire Manual before using this machine.

- 1. Maintenance.** Make sure the jointer is turned off and disconnect from the main power supply and make sure all moving parts have come to a complete stop before any inspection, adjustment or maintenance is carried out.
- 2. Jointer Condition.** Jointer must be maintained for a proper working condition. Never operate a jointer that has damaged or worn parts. Scheduled routine maintenance should be performed on a scheduled basis.
- 3. Blade Condition.** Never operate a jointer with a dropped, cracked or badly worn blade. Before using a jointer inspect all blades. A damaged blade can cause serious injury.
- 4. Hand Hazard.** Keep hands and fingers clear from the cutter-head. Serious injury can occur.
- 5. Leaving a jointer Unattended.** Always turn the jointer off and make sure all moving parts have come to a complete stop before leaving the jointer. Do not leave jointer running unattended for any reason.
- 6. Avoiding Entanglement.** Blade guard must be used at all times. Remove loose clothing, belts, or jewelry items. Never wear gloves while machine is in operation. Tie up long hair and use the correct hair nets to avoid any entanglement with the jointer moving parts.
- 7. Understand the machines controls.** Make sure you understand the use and operation of all controls.
- 8. Power outage.** In the event of a power failure during use of the jointer, turn off all switches to avoid possible sudden start up once power is restored.
- 9. Work area hazards.** Keep the area around the jointer clean from oil, tools, chips. Pay attention to other persons in the area and know what is going on around the area to ensure unintended accidents.
- 10. Work-piece Handling.** Supporting the work-piece adequately at all times while cutting is crucial for making safe cuts and avoiding injury. Never attempt to make a cut with an unstable work-piece.
- 11. Hearing protection and hazards.** Always wear hearing protection as noise generated from cutter-head and work-piece vibration can cause permanent hearing loss over time.
- 12. Cutter-head Alignment.** The top edge of the out-feed table should be aligned with the edge of the knife at top dead centre to avoid kickback. An unaligned table can cause serious injury.
- 13. Joining with the grain.** Jointing against the grain or jointing end grain is dangerous and could produce chatter or excessive chip out. Always joint with the grain.
- 14. Use a Push Stick.** Always use a push stick when whenever surface planing. Never pass your hands directly over the cutter-head without a push stick.
- 15. Blade guards.** Always use blade guards except when rebating. Make sure you replace the guard after rebating.
- 16. Cutting operation.** Always keep the work-piece moving toward the out-feed table until the work-piece has passed completely over the cutter-head. Never back the work-piece toward the in-feed table.
- 17. Stalled blade.** In the case that the cutter-head stalls while in operation, turn the jointer off before freeing the stalled cutter-head.
- 18. Work-piece safety.** Inspect your work-piece carefully before feeding it over the cutter-head. Never joint a board that has knots, nails, or staples.
- 19. Kickback.** Kickback is defined as high speed expulsion of work-piece from the jointer table cutter-head. Never stand in the kickback zone.
- 20. Call for help.** If at any time you experience difficulties, stop the machine and call your nearest branch service department for help.

PLANT SAFETY PROGRAM

NEW MACHINERY HAZARD IDENTIFICATION, ASSESSMENT & CONTROL

Planer Jointer

Developed in Co-operation Between A.W.I.S.A and Australia Chamber of Manufactures
This program is based upon the Safe Work Australia, Code of Practice - Managing Risks of Plant in the Workplace (WHSA 2011 No10)

Item No.	Hazard Identification	Hazard Assessment	Risk Control Strategies <small>(Recommended for Purchase / Buyer / User)</small>
A	ENTANGLEMENT	HIGH	Eliminate, avoid loose clothing / Long hair etc.
B	CRUSHING	LOW	Heavier timber must be supported Be sure that when rising and falling planner tables hands are well away from locating, clamping and pivoting area.
C	CUTTING, STABBING, PUNCTURING	MEDIUM	Isolate power to machine prior to any checks or maintenance. Do not open or clean inside until the machine has completely stopped. Keep hands clear of all blades and moving parts. Use a push stick where necessary. Care must be taken when handling knives. When planing hands must always remain on the top face of the workpiece and never pass over the cutter block (lift hands over cutter block area).
D	SHEARING	MEDIUM	Make sure all guards are secured shut when machine is on.
F	STRIKING	MEDIUM	Do not stand behind timber when feeding into machine. A face mask must be worn at all times. Ensure to use correct feed rates for material.
H	ELECTRICAL	MEDIUM	All electrical enclosures should only be opened with a tool that is not to be kept with the machine.
O	OTHER HAZARDS, NOISE, DUST.	LOW	Wear hearing protection as required. Must be connected to dust extraction

Plant Safety Program to be read in conjunction with manufactures instructions



www.machineryhouse.com.au



www.machineryhouse.co.nz

Authorised and signed by:

Safety officer:

Manager:

Revised Date: 9th August 2016